

EX05

Differentially Pumped, Scanning Ion Gun

Key Words

- Surface Analysis
- Auger Charge Compensation
- Depth Profiling
- ISS
- Sample Cleaning

Introduction

Thermo Electron offers two ion guns, the EX03 and the EX05. The EX03 is intended mainly for sample cleaning prior to surface analysis while the EX05 is designed for high-resolution depth profiles in both XPS and Auger. This document describes the EX05 ion gun, Figure 1. The key features of the gun are:

- Noble gas ions
- Differentially pumped
- Twin filament source
- Two lenses
- Floating drift tube
- Scannable



Figure 1 EX05 Ion Gun

This gun provides a high flux, small spot beam of noble gas ions at energies up to 5 keV. A negative potential can be applied to the drift tube in the EX05 column, this allows better performance at low energy to maximize depth resolution and to enable charge compensation for Auger.

The EX05 from Thermo Electron provides high performance in all surface analysis applications:

- Depth profiling (XPS, AES etc.)
- SIMS
- ISS
- SNMS
- Sample cleaning
- Charge compensation for Auger

Construction

The basic construction of the EX05 is shown in Figure 2.

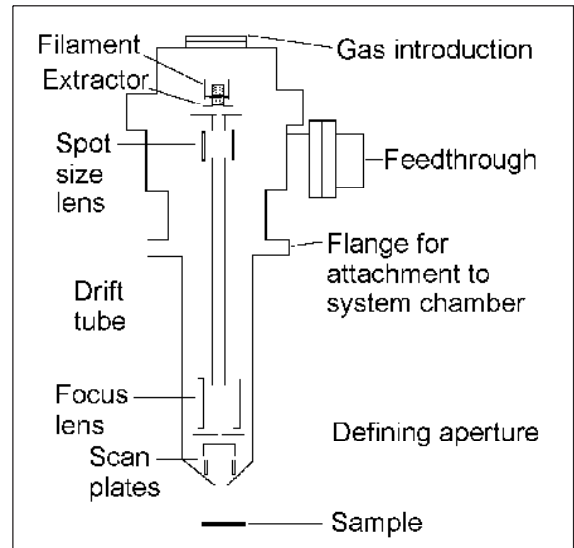

Figure 2 Schematic diagram of the EX05 ion gun.

The source is fitted with two tungsten filaments, one on either side of a cylindrical grid that forms the ionisation region. Only one filament is in use at any time. Fitting a twin filament source allows uptime to be maximised and source maintenance to be a planned event. Selecting the second filament is accomplished by a single switch action.

The ionisation region consists of a cylindrical grid held at a potential of about 70 V positive with respect to the filament. The filament is heated by passing a current through it. The hot filament emits electrons which are attracted to the grid by the ~70 V potential applied to it. This voltage defines the electron energy. The electrons pass into the ionisation region and, because this is surrounded by a region which is at the same potential as the filament, they oscillate within the ionisation region until they strike either the grid or a gas atom. If a gas atom is struck by an energetic electron there is a high probability that it will be ionised. The electron emission current from the filament can be selected by the user; the gun power supply controls the emission current by controlling the current through the filament.

When required, the filaments can be replaced without removing the gun from the system and without disconnecting the differential pumping.

Argon, or another noble gas, is admitted to the ionisation region where a proportion of the gas atoms is ionised by the oscillating electrons. An electrode at the exit from the ionisation region and co-axial with it is held at a negative potential with respect to the grid. This electrode is the extractor and accelerates the ions out of the ionisation region and into the remainder of the ion optical column.

The ion optical column of the EX05 is a two-lens (condenser and focus) design. Between these two lenses is an aperture. For maximum current, the ion beam is focused on the aperture by the condenser lens so that a large proportion of the ion beam passes through it. By changing the potential on the condenser lens, only part of the beam can pass through the aperture and so the beam current can be controlled.

If the ion gun is controlled by the standard controller, a negative potential can be applied to the drift tube when the gun is operated at low energy. This increases the current available from the ion gun at the low energy.

Following the lenses is a set of scan plates which consist of two pairs of parallel electrostatic plates which can scan or shift the beam in the x and y directions.

Because this ion gun requires a relatively high flow of gas into the source, it is usually necessary to differentially pump the source so that a good vacuum is maintained in the analysis chamber. The differential pumping aperture is very close to the source region to minimise the distance that the ions travel in the high-pressure region of the gun. This reduces the proportion of the ions that are converted to fast atoms to a level where they have a negligible effect on depth profiling performance.

Power Supply

The EX05 features a digital power supply controlled by the advanced *Avant age* data acquisition and processing software package. *Avant age* provides control of all the operating parameters of the source and column. The data system also controls all aspects of ion beam scanning.

Characteristics

Usable ion currents can be obtained from the EX05 in the energy range 100 eV to 5 keV. This is partly as a consequence of the negative potential which can be applied to the drift tube in the column.

The spot size characteristics of the ion gun depend upon its working distance. Figure 3 shows typical characteristics of the ion gun when the working distance is 20 mm and Figure 4 shows the same characteristics at 70 mm. The maximum current density is >5 mA/cm².

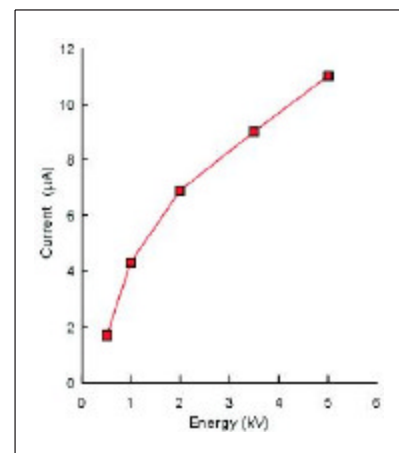
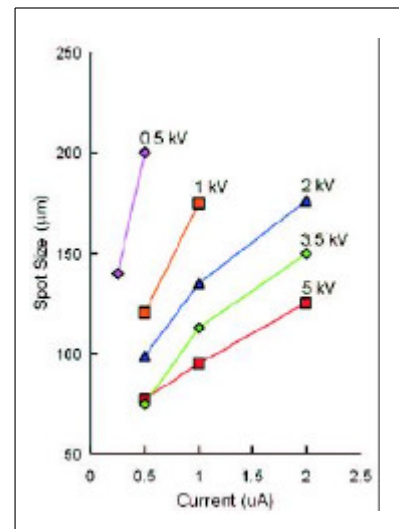
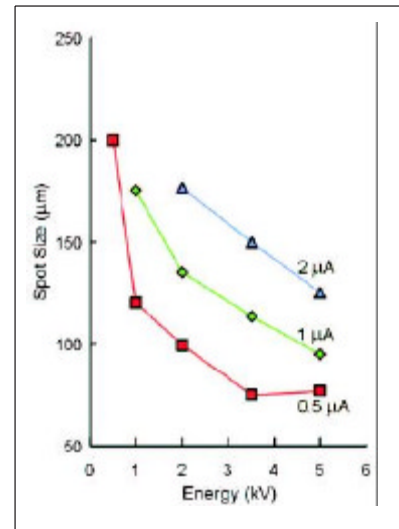

Figure 3 EX05 characteristics at 20 mm working distance.

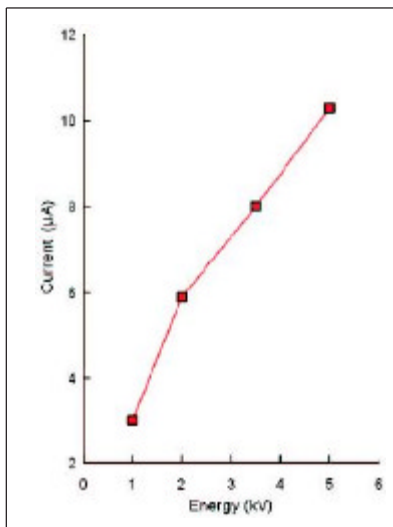
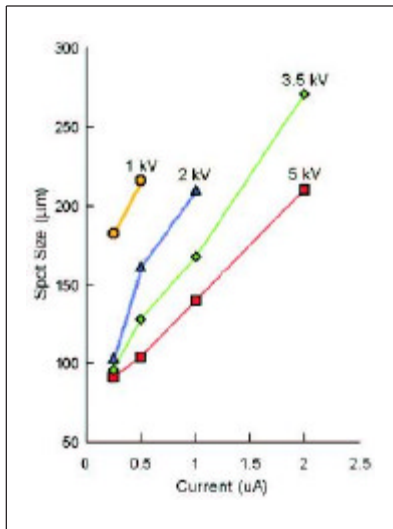
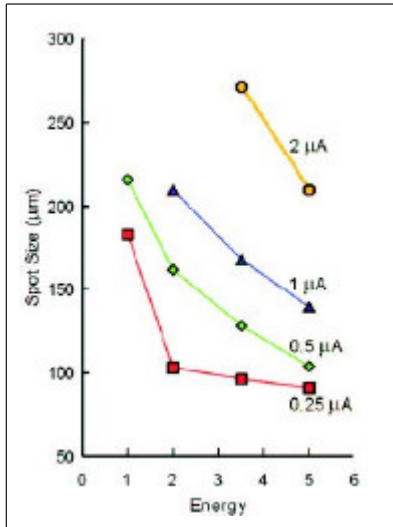

Figure 4 EX05 characteristics at 70 mm working distance.

Operating Conditions

The choice of operating conditions depends upon the experimental requirements. Maximum etch rate requires the maximum current density, this is achieved at 5 keV and with a small scanned area. This set of conditions may not, however, produce good depth resolution, because that requires the use of a low energy ion beam to minimise atomic mixing.

For optimum depth resolution the beam energy should be low (e.g. <1 keV) and the crater size should be large in relation to the ion beam diameter.

There is no general rule for deciding which conditions to use because in all cases a compromise must be reached between speed of analysis and the required depth resolution. This will depend to some extent on the type of sample being analysed. For example, if the sample has a rough top surface then it will be unnecessary to use a very low beam energy because the inherent sample roughness will put a limit on the depth resolution which can be achieved.

Depth Profiles

The EX05 is fitted to all of Thermo Electron's surface analysis instruments because of its excellent depth profiling capabilities. Figure 5 shows an example of a depth profile through a metal multi-layer sample. It can be seen that the depth resolution is maintained throughout the whole of the profile (more than 500 nm).

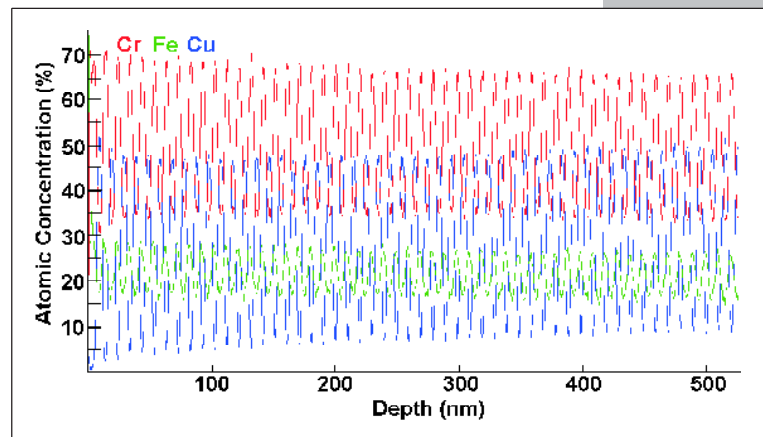

Figure 5 Depth profile through a metal multi-layer material showing excellent depth resolution throughout. This is an Auger depth profile acquired using the EX05 on a MICROLAB 350 instrument.

Ion Scattering Spectroscopy

The energy spread of ions in the beam from the EX05 is small making it ideal for ion scattering spectroscopy (ISS). For example, Figure 6, shows part of the ISS spectrum from copper. As can be seen, both isotopes of copper are visible. This indicates that the gun can be operated in such a way that the beam has a very small energy spread.

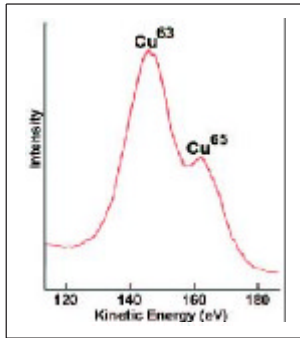

Figure 6 Part of the ISS spectrum from copper showing that the two isotopes can be resolved using the EX05 ion gun. (Ar ions at 1 keV).

Charge Compensation

The EX05 can be operated at very low beam energy (<100 eV). This is possible because a positive potential can be applied to the drift tube. Such lower energies can be useful, for example, in neutralising charging in AES and SEM acquisitions (see application note ANB0015).

Summary Specifications

Table 1 shows a summary of the important specifications for the EX05.

Energy range	0.1 to 5 keV
Maximum current	>10 μ A
Spot size	<120 μ m
Working distance (WD)	15 to 60 mm (15 mm optimal)
Maximum scan area at 5 kV	2.5 x 2.5 mm (15 mm WD) 10 x 10 mm (60 mm WD)
Gas species	Inert gases
Mounting flange	70 mm OD

Table 1

Dimensions

The ion gun dimensions are shown in Figure 7 and the pumping and gas feed requirements are shown in Figure 8.

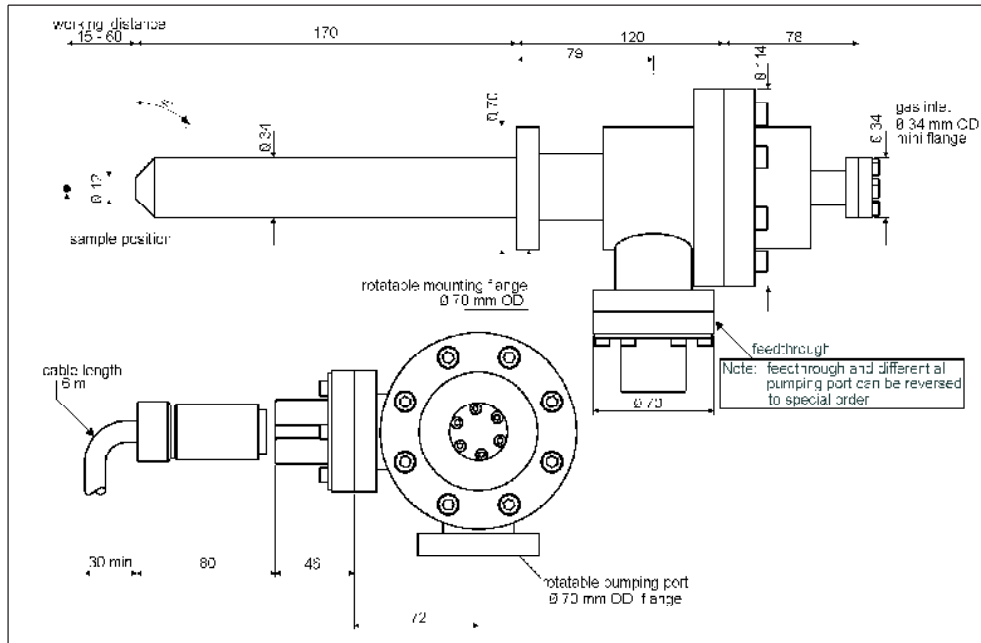

Figure 7 EX05 dimensions.

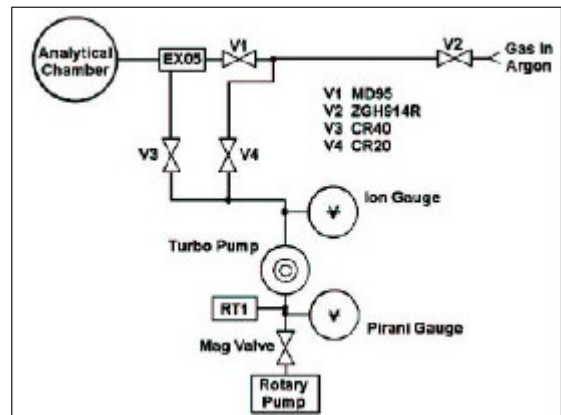

Figure 8 Pumping, gauging and gas feed requirements for EX05.

Thermo Electron Corporation maintains a network of offices throughout the world. For detailed technical information please contact +44 1342 327211.

Australia
+61 2 98 98 1244

Austria
+43 1 333 50340

Belgium
+32 2 48 2 30 30

Canada

China
+86 10 58 50 358 8

France
+33 1 60 9 2 48 00

Germany
+49 6103 408 0

Italy
+39 02 950 59 1

Japan
+81 45 453 9 100

Netherlands
+31 76 58 7 9 8 8 8

Norway
+46 8 556 468 00

South Africa
+27 11 570 18 40

Spain
+34 9 1 657 49 30

Switzerland
+41 61 48 78 4 00

UK
+44 1442 233555

USA
+1 800 532 4752

www.thermo.com



Thermo Electron, Surface Analysis Instruments, East of Ireland, UK is ISO certified.

©2004 Thermo Electron Corporation. All trademarks are the property of Thermo Electron Corporation and its subsidiaries.

Specifications, terms and pricing are subject to change. Not all products are available in all countries. Please consult your local sales representative for details.

AN30061_E_03/04

Thermo
ELECTRON CORPORATION